

884 MC THREE-PHASE

for sliding gates
with max weight of 3.500 kg



■ Steel housing

■ Door with key lock

■ Designed for industry

The FAAC 884 gearmotor was designed to move the heaviest industrial gates in the simplest and safest way. "Industrial" duty is assured by the gearmotor's exceptional performance, enabling intensive use frequency also for gates weighing 3.500 kg.

■ The character of steel

The special twin-disk clutch, in oil bath, enables drive torque adjustment from 0 to 155 daN. The steel housing - cataphoresis treated and polyester painted - is highly resistant to any environmental aggression, offering reliability to meet the most severe demands.

■ Intelligent technology

Automation is controlled by a high-tech control board with microprocessor, which controls all the necessary functions and is designed for connection to control, safety and signalling devices.

■ Guaranteed long-life

Constant oil-bath lubrication of mechanical components plus assembly in a high resistance pressure-cast enbloc aluminium body ensure extremely long operator life.

■ Irreversible

In case of emergency, the braking device guarantees leaf stop within very limited space, thus improving anti-crushing safety. The device also ensures the gate stays closed, so there is no need to install electric locks or bolts. In case of a power failure, a special key-protected release lever allows the gate to be opened and closed manually.

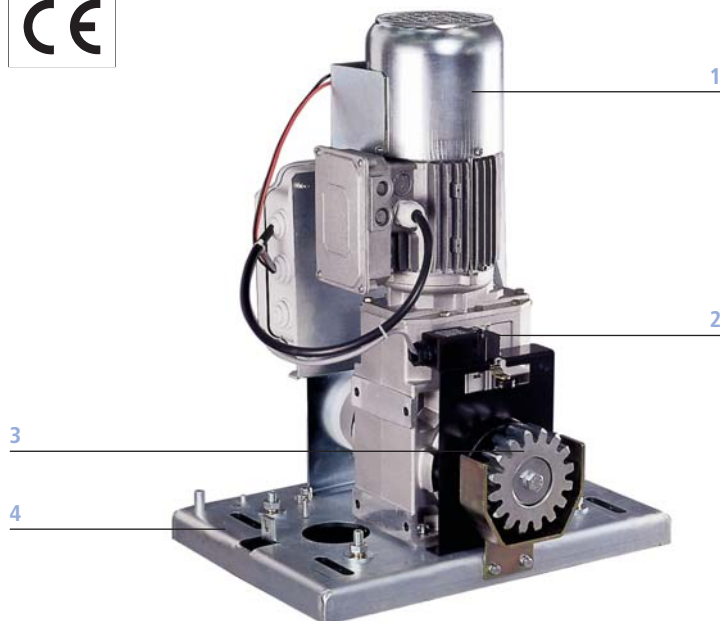

- 1 Self-braking electric motor
- 2 Mechanical limit-switch
- 3 Pinion Z16 M6
- 4 Base with adjusting screws
- 5 Release lever with safety microswitch
- 6 884 T control board

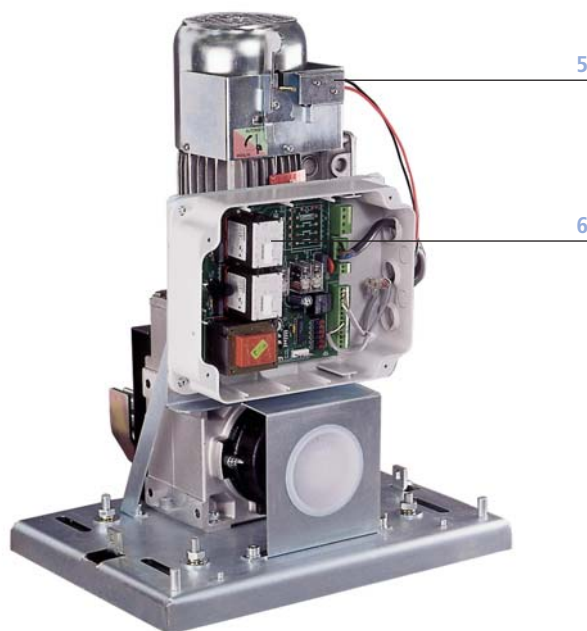

DIMENSIONS

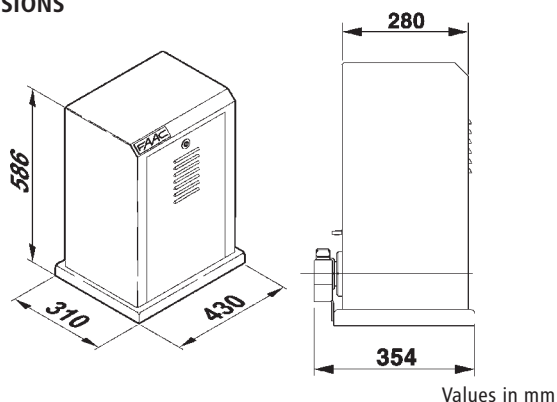

Technical specifications	884 MC THREE-PHASE
Power supply	230 Vac 3ph (+6% -10%) 50 (60) Hz 400 Vac 3ph (+6% -10%) 50 (60) Hz
Absorbed power	850 W
Absorbed current	2.7 A(230V) - 1.6 A(400V)
Torque	from 0 to 155 Nm
Motor rotation speed	1.400 rpm
Reduction ratio	1:43.2
Operating ambient temperature	-20°C ÷ +55°C
Weight	50 kg
Protection class	IP 55
Type of oil	FAAC oil XD 220
Gate speed	10 m/min (Z16)
Limit-switch	With lever and roller microswitch
Clutch	Twin disk in oil-bath

Specifications of 884 T control board	
Power supply	230 Vac 3ph (+6% -10%) 50 (60) Hz 400 Vac 3ph+N (+6% -10%) 50 (60)
Motor maximum load	Hz
Accessories output	1300 W
Operating ambient temperature	24 Vdc 500 mA max -20°C ÷ +55°C
Power supply to indicator-light	24 Vac (5W max)
Two protection fuses	5 A transformer 1.6 A accessories
Safety timer	255 sec.

Inputs - Open, partially open, stop, closing safety devices, limit-switch
Outputs - Indicator-light, flashing lamp, motor, 24 Vdc power supply for accessories
Programming - Pause time (5/10/15/30/60/120/180 sec.), logics A1/A2/S1/S2/E1/E2/B/C, pre-flashing.

Model	Use		Control board
	Max weight (kg)	Use frequency (cycles/hour)	
884 MC THREE-PHASE	3.500	50 100 (2.000 kg)	884 T included